

# Empower<sup>2</sup>

ADVANCED SMILE TECHNOLOGY<sup>®</sup>



**AO AMERICAN**  
ORTHODONTICS  
3524 Washington Ave  
Sheboygan, WI 53081 USA

REF 126-029935  
1 PAT SETUP SL EMPOWER CLEAR ACT ROTH D22-UIL

LOT N50828  
QTY: 20 PIECE(S)  
5x5 WHK 3 DROP-IN  
MADE IN USA

CE 1434  
1 PAT SETUP SL EMPOWER CLEAR ACT ROTH D22-UIL  
See www.americanortho.com for Symbol Glossary • S-039209 REV00



Founded in 1968 and headquartered in Sheboygan, Wisconsin, American Orthodontics is committed to providing quality products, dependable delivery, and personalized service to the orthodontic specialist. With over 800 global employees and product availability in over 110 countries, American Orthodontics is one of the largest privately held manufacturers of orthodontic appliances in the world.

Almost all AO products are made in the United States, with nearly 98% produced in Sheboygan, maximizing efficiency throughout our state-of-the-art 280,000 square foot facility. Operations and office functions are under one roof, offering the utmost control over product quality and cost containment. Manufacturing processes are tightly controlled to comply with medical device regulations in all areas and regions of the world. By building its own team of automation engineers that design the company's machinery and continued investment in manufacturing technologies, AO has built a factory unlike any other in the orthodontic industry.

Whether entering new markets, registering or renewing products, or leading clinical education in our industry, American Orthodontics works tirelessly to ensure all regulatory and industry standards are met or exceeded.

- **AO is one of the first to achieve Unique Device Identification (UDI) compliance, ensuring global requirements are met to improve transparency of medical device product information for consumers, distributors, clinicians, and patients.**
- **All required products are registered with the FDA**
- **ISO 13485:2016 certified**
- **Products are CE marked for European Union**
- **Medical Device Single Audit Program (MDSAP) certified, a program that demonstrates compliance in Australia, Brazil, Canada, Japan, and the United States.**



Our experienced and dedicated customer service and shipping teams deliver orders complete and on time to multiple locations in different countries. Whether your business requires one annual order or periodic shipments based on location or budget, AO delivers.

Doctors and Clinical Support Teams recognize the award-winning quality of AO products. Since 2014, the inaugural year of the Orthotown Townie Choice Awards, American Orthodontics has been recognized by orthodontists as Best in Class more than any other orthodontic product manufacturer. Other honors earned include awards for manufacturing, local economic impact, and international marketing awards.



# Empower<sup>®</sup> 2

## Self Ligating Braces

### MORE CHOICE. THAT'S EMPOWER 2.

The breadth of the Empower<sup>®</sup> 2 line is unequaled. You get the most features, prescription choices\*, and treatment possibilities all in one quality, unified system.

### BRACKET CHOICES

- Empower 2 Clear brackets combine performance with patient-pleasing aesthetics.
- Empower 2 metal brackets provide self ligating benefits in a comfortable, low profile design.

### SYSTEM CHOICES

- The Dual Activation™ System of Empower 2 combines interactive brackets on the anterior teeth with passive brackets on the posterior teeth in one unified system.
- Fully interactive system allows exceptional torque and rotation control during all phases of treatment. This interactive self ligating system offers the benefits of less friction at the beginning of treatment and more control in the later stages to assist with final torques and rotations.
- Fully passive system allows lower friction sliding mechanics throughout treatment as no wires are actively engaged by the clip.



\*Ask your sales representative for RX options.

Empower® SL  
**DUAL** Activation™  
S Y S T E M

## ONE SYSTEM. MULTIPLE APPLICATIONS. ZERO COMPROMISE.

American Orthodontics pioneered and patented the Dual Activation System with the introduction of Empower Self Ligating Brackets. The Dual Activation System is a single, innovative concept with multiple applications — all designed to enhance your treatment philosophy. Utilizing Empower 2 and Dual Activation delivers the time-saving benefits and ease of self ligation, while allowing you to treat your patients your way using the best of both interactive and passive systems.

The best of both worlds - interactive and passive brackets in one unified system. Designed and engineered to deliver torque expression, tolerance tightness is maximized when Empower 2 is coordinated with arch wire from American Orthodontics. Empower 2 owns three patents: Patented Empower 2 Bracket Utility (10,111,731), Empower2 Bracket Design (D820,457), and Empower 2 Molar Design (D797,294).

- Interactive brackets on anterior teeth for full control and a precise finish
- Passive brackets on posterior teeth for improved posterior freedom play
- Matching in/outlets between interactive and passive designs means no 1st order wire bending compensations
- Time saving benefits and ease of self ligation
- Metal and clear options

*“Dual activation gives you active SL in the anterior where we **need more control** on torque and passive SL in the posterior where, generally speaking, torque demands are not as great. Using sliding mechanics to close spaces also **helps eliminate friction** or the need to use the bi-dimensional bracket setups which aim to do the same thing.” — Dr. Matthew Ng*



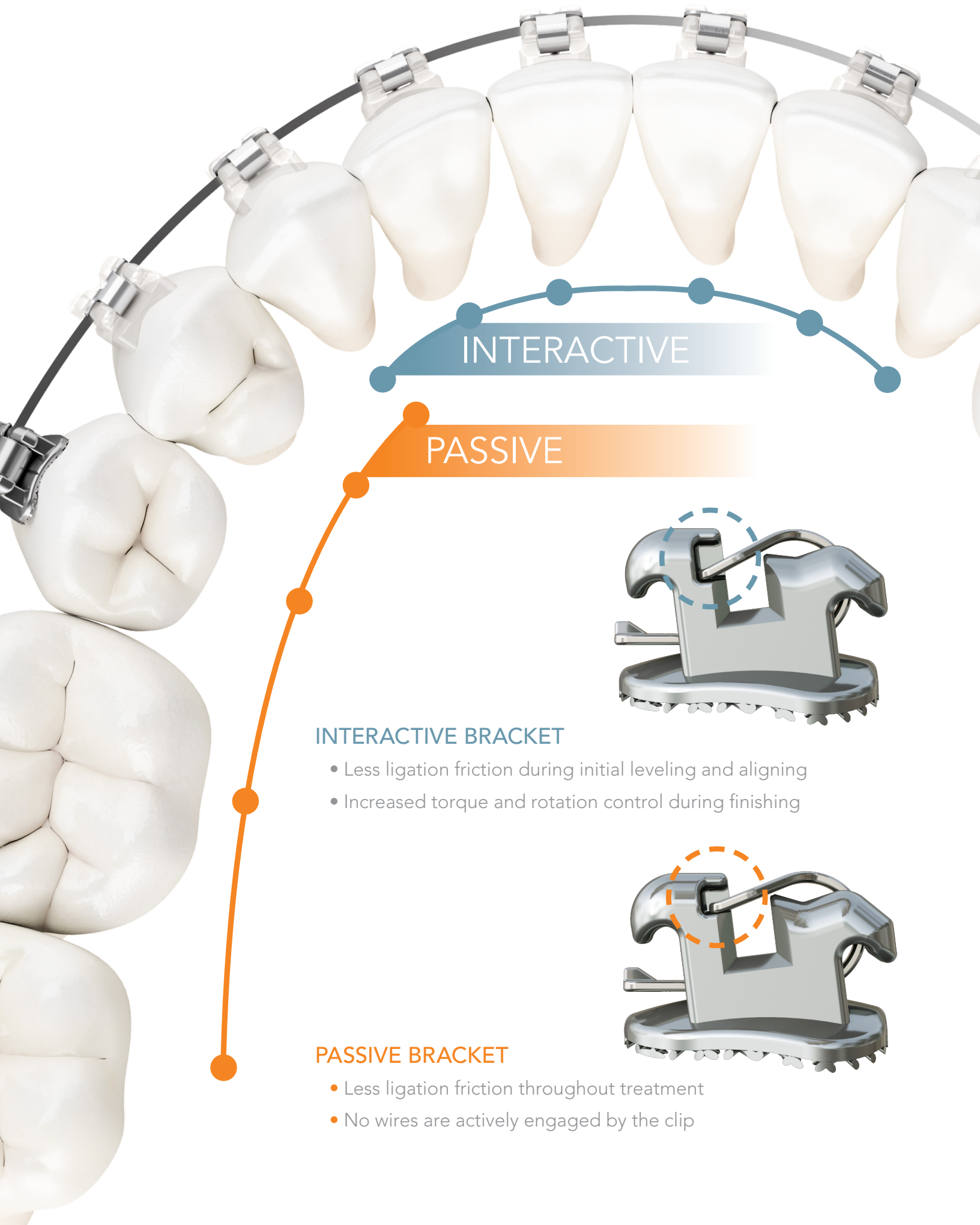

INTERACTIVE

PASSIVE

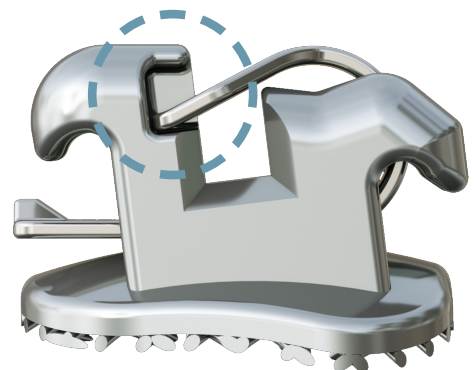

**INTERACTIVE BRACKET**

- Less ligation friction during initial leveling and aligning
- Increased torque and rotation control during finishing

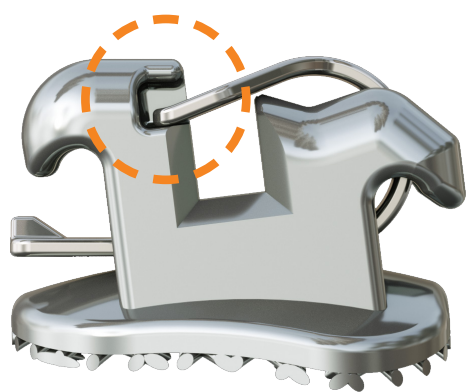

**PASSIVE BRACKET**

- Less ligation friction throughout treatment
- No wires are actively engaged by the clip

# Empower<sup>®</sup>2

Clear Self Ligating

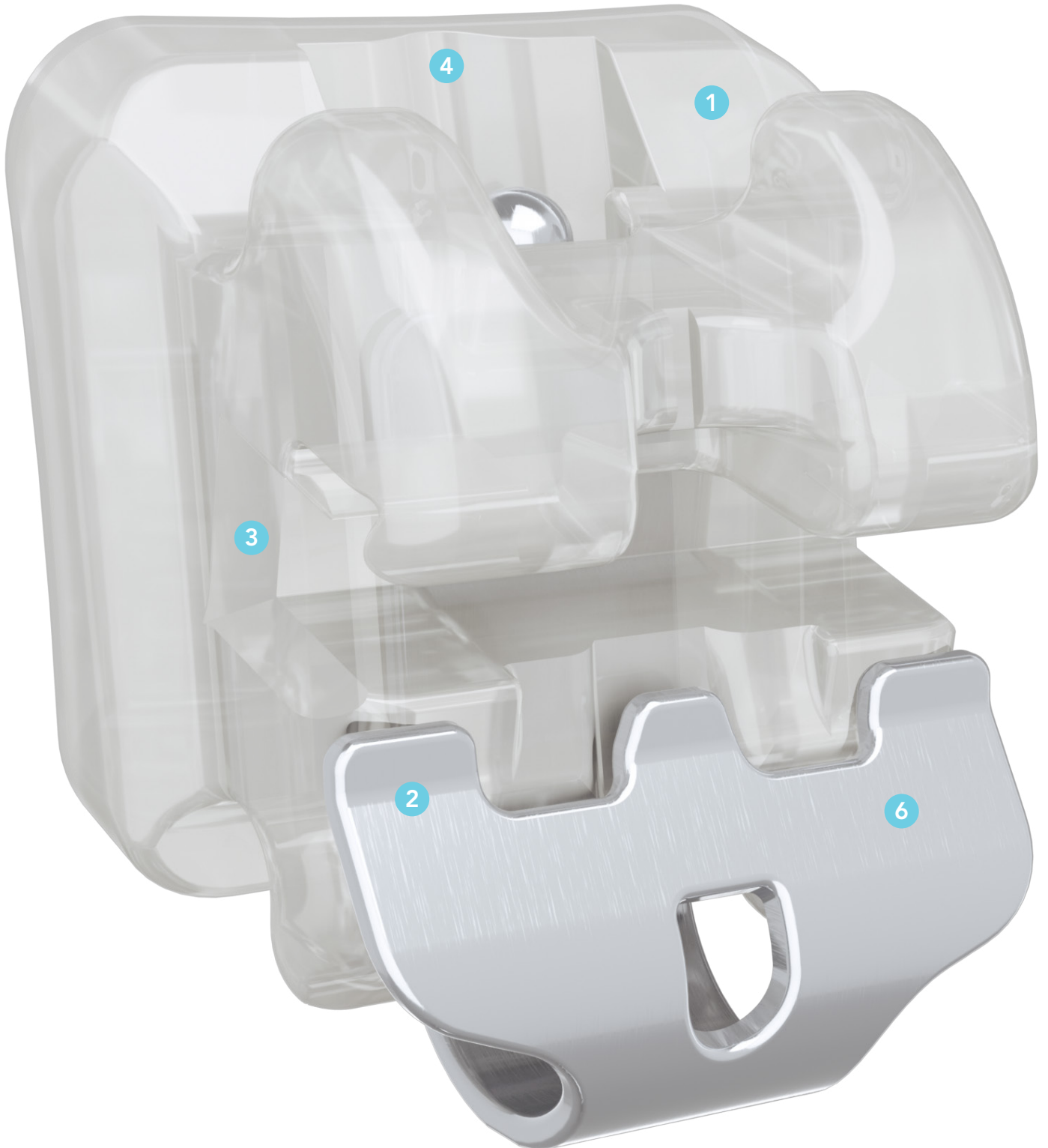



Empower 2 Clear brackets are a patient-pleasing aesthetic option giving you the versatility and ease of self ligation while providing your patients the beautiful smile they deserve.

## 1. ROBUST BRACKET BODY DESIGN

Enhanced durability without sacrificing tie-ability

## 2. PATENTED MULTI-POINT CLIP

Helps seat wire into slot during closure. Adds visual cue to confirm clip closure

## 3. CHAMFERED SLOT ENTRANCE

Reduces friction from wire binding

## 4. REDESIGNED CLIP TRACK

Ample relief for the clip track provides easier opening

## 5. SIMPLIFIED DEBONDING

Patented Quad Matte® lock base technology is refined to offer more predictable debonding

## 6. RELIABLE, ROBUST CLIP

Stronger, thicker clip increases wire seating force and reduces clip deformation



## PRESCRIPTION CHOICES\*

- McLaughlin, Bennett, Trevisi
- Roth Compatible
- CCO Modified
- Additional Torque Options

## BRACKET OPTIONS

- Metal Self Ligating Brackets
- Clear Self Ligating Brackets
- Reconvertible Self Ligating Molar Tubes
- Interactive Brackets
- Passive Brackets
- Optional, integrated hooks on laterals, cuspids, and premolars

## TREATMENT OPTIONS

- Fully interactive system
- Fully passive system
- Dual Activation System

## WIRE CHOICES

- Tanzo® Premium Heat Activated Arch Wire (Copper Nickel Titanium)
- Nickel Titanium Superelastic NT3®
- Beta Titanium
- Stainless Steel
- Iconix Rhodium Coated Arch Wire
- Tritanium Multi-Force Heat Activated NiTi
- Thermo-Ti Heat Activated NiTi

\* American Orthodontics' prescription versions.  
No endorsement by the doctor(s) is implied.

# Empower<sup>®</sup>2

Self Ligating

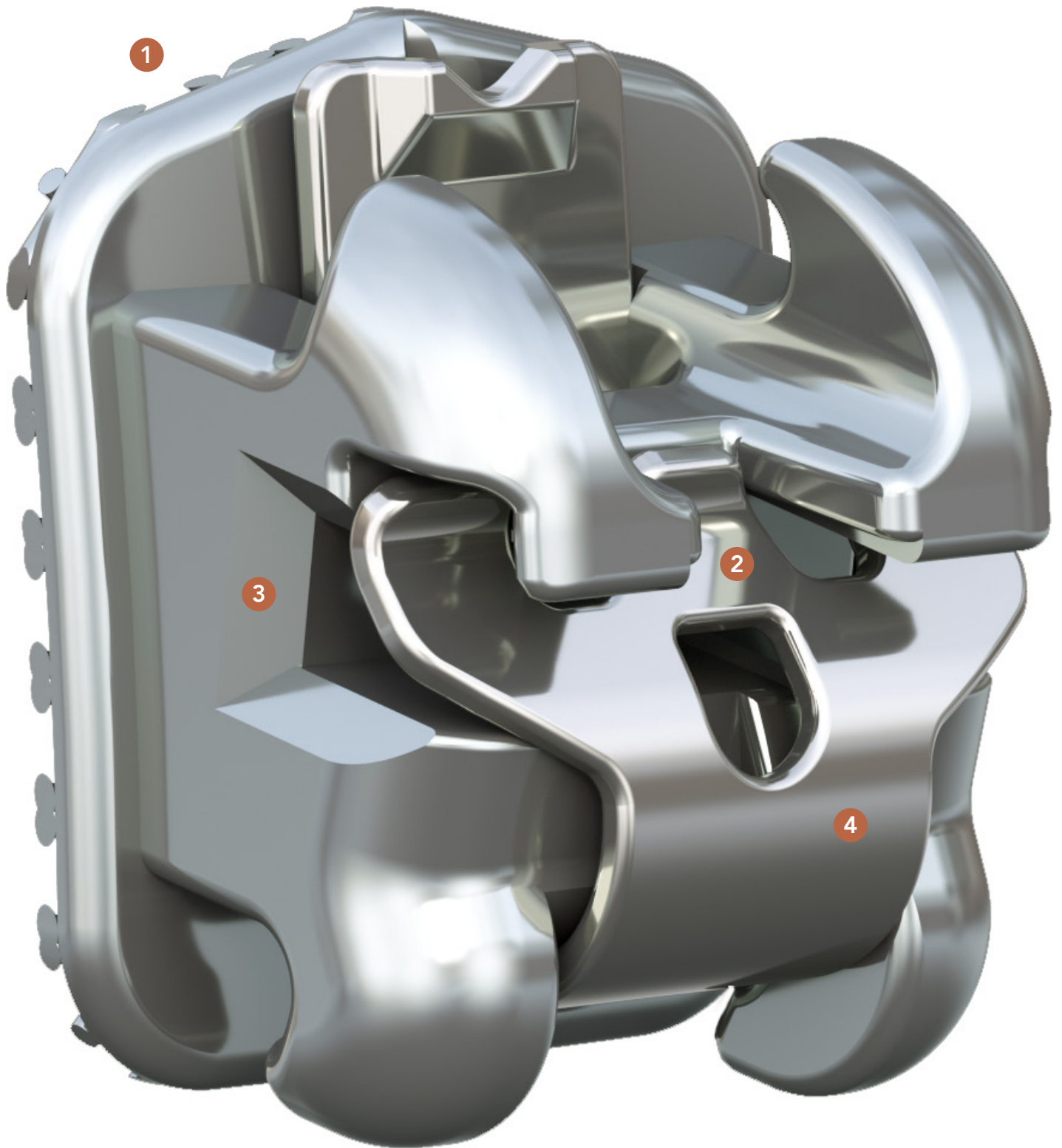

Empower 2 metal brackets deliver the performance you need with features that enhance the strength and dependability of the bracket. Empower 2 metal brackets give you the choice of a fully interactive, fully passive, or combination Dual Activation System.

### 1. MICRO ETCHED MAXIMUM RETENTION™ BONDING PADS **MR**

Increases bond strength 15-30% over non-micro etched pads

### 2. PATENTED MULTI-POINT CLIP

Helps seat wire into slot during closure. Adds visual cue to confirm clip closure

### 3. CHAMFERED SLOT ENTRANCE

Reduces friction from wire binding

### 4. RELIABLE, ROBUST CLIP

Strong, thick clip increases wire seating force and reduces clip deformation



## PRESCRIPTION CHOICES\*

- McLaughlin, Bennett, Trevisi
- Roth Compatible
- Modified Damon
- Roncone
- Andrews
- Gianelly V-Slot
- CCO Modified
- Additional Torque Options

## BRACKET OPTIONS

- Metal Self Ligating Brackets
- Clear Self Ligating Brackets
- Reconvertible Self Ligating Molar Tubes
- Interactive Brackets
- Passive Brackets
- Four premolar pad choices
- Optional, integrated hooks on laterals, cuspids, and premolars

## TREATMENT OPTIONS

- Fully interactive system
- Fully passive system
- Dual Activation System

## WIRE CHOICES

- Tanzo Premium Heat Activated Arch Wire (Copper Nickel Titanium)
- Nickel Titanium Superelastic NT3
- Beta Titanium
- Stainless Steel
- Iconix Rhodium Coated Arch Wire
- Tritanium Multi-Force Heat Activated NiTi
- Thermo-Ti Heat Activated NiTi

\* American Orthodontics' prescription versions.  
No endorsement by the doctor(s) is implied.

# BOND WITH CONFIDENCE

The pads and bases of Empower 2 deliver the bonding strength you demand and help reduce the risk of emergency appointments due to debonding.

## EMPOWER 2 CLEAR SELF LIGATING

The patented mechanical lock base of Empower 2 Clear incorporates alumina particles on the center of the base for easy and predictable debonding.



## EMPOWER 2 SELF LIGATING MAXIMUM RETENTION BONDING PADS **MR**

The micro-etched Maximum Retention bonding pads on Empower 2 metal brackets and tubes increase bond strength 15-30% over non-micro etched pads. Photo-etched pockets lie beneath 80-gauge mesh to increase pad surface area and ensure safe, secure bonds.



# PREMOLAR PAD OPTIONS

Multiple premolar pad designs offer choices tailored to your treatment goals. Palmer notation is laser marked on the pads for ease of bracket identification and organization.

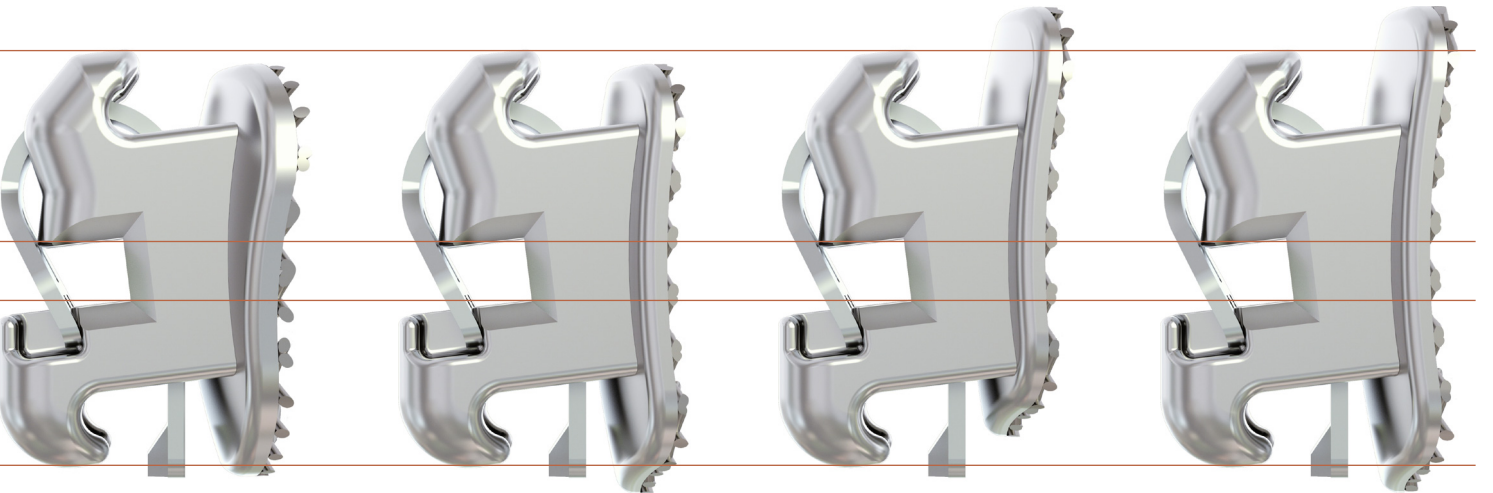
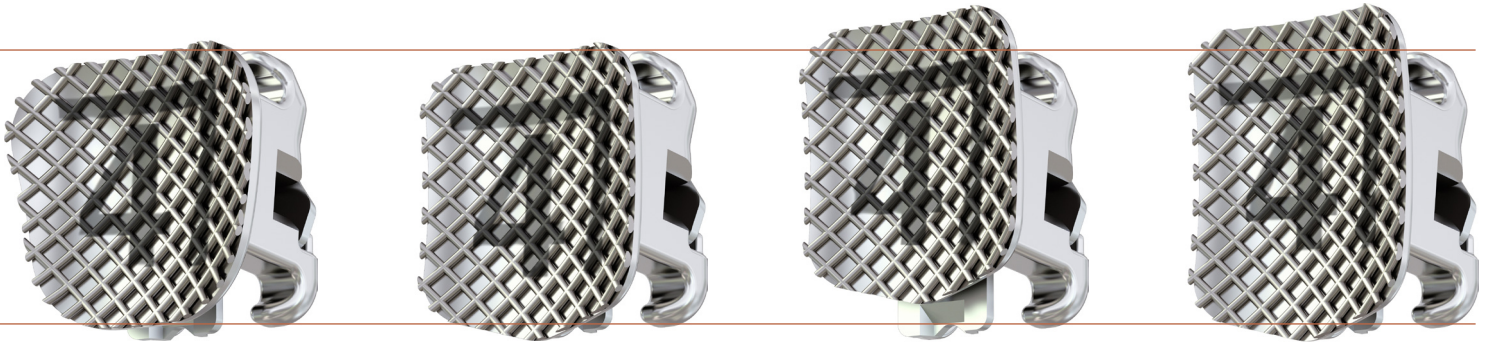

## **BX PAD**

Our most advanced pad is slightly larger than standard pads, with a trapezoid shape and enhanced pad curvature to deliver excellent fit and bond strength.

## **STANDARD PAD**

Slightly larger than a twin bracket pad, it extends gingivally past the clip tail for easier engagement of tail during opening.

## **TRUE OFFSET PAD**

Standard pad size positioned toward the gingival for easier bonding on shorter clinical crowns, making indirect bonding easier.

## **EXTENDED OFFSET PAD**

15% larger surface area than standard pads for greater bond strength.

# EASY OPEN. EASY CLOSE.

The entire Empower 2 family utilizes one double-ended opening instrument providing two opening methods that work for both Empower 2 metal brackets and Empower 2 Clear brackets.



## SINGLE PRONG TIP

Engages clip tail on Empower 2 metal brackets and Empower 2 Clear brackets.

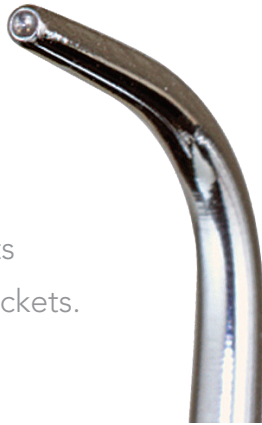

## TWO-PRONG TIP

Engages facial hole on entire Empower 2 family and serves as the preferred opening method.

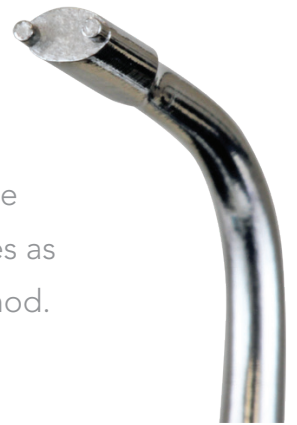

## CLOSING

All Empower 2 clips snap closed easily with simple finger pressure.



# SIMPLE DEBONDING

Now debonding aesthetic brackets is made simple with American Orthodontics.

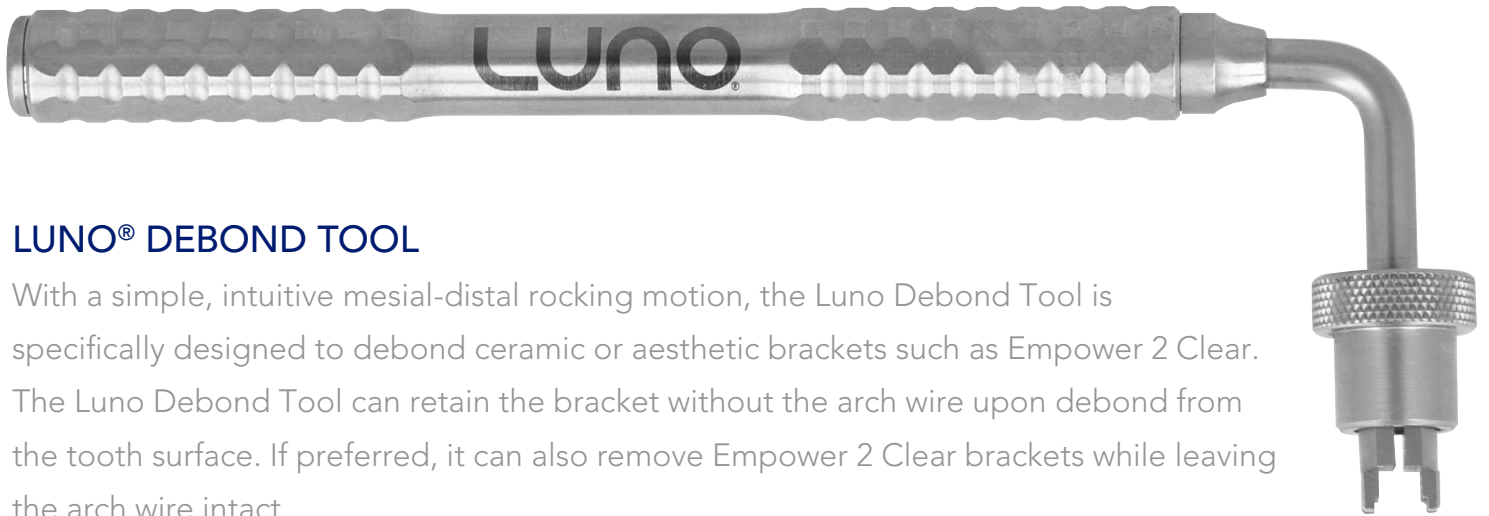

## LUNO® DEBOND TOOL

With a simple, intuitive mesial-distal rocking motion, the Luno Debond Tool is specifically designed to debond ceramic or aesthetic brackets such as Empower 2 Clear. The Luno Debond Tool can retain the bracket without the arch wire upon debond from the tooth surface. If preferred, it can also remove Empower 2 Clear brackets while leaving the arch wire intact.

Just like every Luno cutter, bender, and plier, the Luno Debond Tool is precision manufactured to effectively prevent corrosion and is tested beyond industry standards. Each Luno instrument is laser engraved with lot numbers to assist in quality control and ensure it is the right instrument for the right job.



## LUNO CERAMIC (SUSHI) DEBONDING PLIERS

The blades of these "sushi" pliers are parallel when placed along the mesial and distal sides of the bracket. Only the upper surfaces of the tips are sharpened, focusing the debonding force at the bracket/enamel interface.



## DR. DAN BILLS

Dr. Dan Bills received his Bachelor of Arts degree in Biology from Lafayette College and his dental degree from Harvard University, both with Honors, after which he completed a three-year orthodontic residency at the University of Illinois. He is a Board Certified Diplomate of the American Board of Orthodontics and a Fellow of the American College of Dentists. He maintains a state-of-the-art private practice, Innovative Orthodontics, with three locations in Southern New Jersey, just outside of Philadelphia. He has been honored as “Teacher of the Year” by the University of Pennsylvania Department of Orthodontics and by the Department of Dentistry at Virtua Hospital. He lectures regularly at academic institutions and orthodontic meetings, both stateside and abroad, and gives in-office courses about a variety of clinical topics as well as how to better utilize technology in the orthodontic office. One of his greatest passions is teaching his colleagues how to work smarter and, consequently, live better.

*“I was **amazed** from the start with the **positive** changes Dual Activation brought and how much **easier** it was for me to **finish my cases**.”*

My treatment philosophy is built on creating beautiful smiles and healthy bites in the most efficient way possible. This involves lateral arch development, differential arch forms, and a tremendous attention to detail during the finishing stages of treatment. The Empower Dual Activation System of Empower 2 has allowed me to achieve all of these things in a more efficient and effective way than the popular passive self ligating bracket system I used previously for over a decade. With this previous system, I found I had to work extremely hard with differential torque options and needed excessive detailing to finish my cases.

Dual Activation has allowed me to enjoy the benefits I have come to expect from a passive system, including rapid alignment and minimal friction, but with the added benefit of an easier and more predictable finish. I’m doing much less wire bending, and I find the system practically eliminates the need for differential torque brackets, which translates to a lower inventory and therefore a savings of both cost and time.



# MY RX: DR. DAN BILLS

## BRACKETS: .022

Empower 2 — Roth Compatible U2-2, McLaughlin, Bennett, Trevisi\* on remainder of teeth

Interactive U/L 3-3, Hooks on 3's

Passive U/L 4, 5, Hooks on the U4's and L4's and 5's

iFit® Molar Tubes on 6's

Mini Master® Molar Tubes on 7's

## WIRE

VLP Arch Form

Initial Alignment and Leveling

**.014 Tanzo to the 6's and .018 Tanzo to the 7's**

Early Torque Control & Lateral Development

**.020 x .020 Tanzo** (All Tanzo and mid-force with pre-loaded stops)

Finishing

**.018 x .025 Stainless Steel Upper**

**.018 x .025 Stainless Steel Lower**

## TIPS, TRICKS, AND INSIGHTS

I no longer need differential torque brackets and my detailing is minimal, since the full prescription in the brackets is expressed at the end of treatment.

I utilize differential VLP arch forms in 3 different sizes (L, M, S), thus allowing me to utilize coordinating arch forms for the upper and lower during the lateral development and finishing stages of treatment. Because of this, I am able to avoid both the over expansion of patients with smaller teeth and the creation of iatrogenic crossbites that are inherent with a one-size-fits-all wire philosophy.

I prefer higher negative torque upper molar tubes to counteract tipping forces generated during lateral development of the arch.

\* The American Orthodontics version of the McLaughlin, Bennett, Trevisi System does not claim to be a duplication of any other, nor does American Orthodontics imply they are endorsed in any way by Drs. McLaughlin, Bennett, or Trevisi.



## DR. ED LIN

Dr. Ed Lin is one of two partners at Orthodontic Specialists of Green Bay (OSGB). He is also one of two partners at Apple Creek Orthodontics of Appleton (ACO). Dr. Lin received both his dental (DDS) and orthodontic (MS) degrees from Northwestern University Dental School. OSGB and ACO are all completely digital practices and have been utilizing intraoral scanning and SureSmile since February of 2004 at three different practice locations for labial, lingual, and aligner treatments. All practices have been involved with cone beam computed tomography (CBCT) with the iCAT since 2005. In-House 3D printing has been incorporated since 2014 and all practices have been impression free for over 5 years. In-house aligner therapy is an important part of all practices, having treated over 1200 aligner cases in 2019.

Dr. Lin is an internationally recognized speaker, has written several articles that have been published in a wide variety of dental journals, and has lectured at several orthodontic residency programs across the world. He is a Faculty and Clinical Advisory Board Member for SureSmile. He is also a Key Opinion Leader for American Orthodontics, Imaging Sciences International, Envision TEC, and Hu-Friedy. He is a past member of the American Association of Orthodontists Committee on Technology and is on the Editorial Board of OrthoTown and Orthodontic Practice journals. Dr. Lin's passion for both orthodontics and technology has allowed him to integrate them into his clinical practices in his pursuit of clinical excellence to be able to provide the highest quality of care for his patients.

*"All doctors in our 3 practices are **firm believers** with Empower 2 for all orthodontic cases including Phase I cases. The Empower 2 self ligating bracket gives our entire clinical team **confidence** with **quick, efficient, and comfortable** reties for our patients so that we can see more patients in our set clinical hours."*

# MY RX: DR. ED LIN

## BRACKETS: .018

Empower 2 — McLaughlin, Bennett, Trevisi\*  
Interactive U/L 5-5, Hooks on 3's, 4's, and 5's  
Empower 2 Molars on 6's

## WIRE

Arch Form I or III  
Initial Alignment and Leveling  
**.014 or .016 Therma-Ti**  
Torque Control  
**.016 x .016 Tri-Tanium**  
**.018 x .018 Tri-Tanium**  
Finishing  
**.016 x .022 SureSmile® Copper NiTi or .017 x .025 SureSmile Copper NiTi**

## TIPS, TRICKS, AND INSIGHTS

All doctors in our practices are firm believers with the interactive clip as we are all SureSmile doctors and we want SureSmile's prescription wire expressed with the bracket. Slop is not good with SureSmile. As a result, we are an .018 slot and finish with a .017 x .025 SureSmile Copper NiTi Wire. This .017 x .025 SureSmile Copper NiTi wire will fill the slot better than an .022 slot with a .019 x .025 wire which will have more slop. With integrating and leveraging technologies together, Empower with SureSmile gives our practices the ability to optimize maximum clinical efficiency which results in superior treatment results, fewer appointments for our patients, and happier patients.

\* The American Orthodontics version of the McLaughlin, Bennett, Trevisi System does not claim to be a duplication of any other, nor does American Orthodontics imply they are endorsed in any way by Drs. McLaughlin, Bennett, or Trevisi.



## DR. SHADOW ASGARI

Dr. Shadow Asgari is a native of Houston, Texas and moved to Arizona in 2002 to begin her practice in orthodontics. She received her dental and orthodontic degrees from University of Texas Health Science Center, the largest medical center in the world.

While studying at the Texas Medical Center, Dr. Asgari had the opportunity to collaborate with some of the best scientific minds on groundbreaking research. She has contributed to the field of orthodontics on several published research projects. The daughter of a scientist, Dr. Asgari spent quite a bit of time as a child in her father's laboratory learning the scientific method. She still uses the scientific method when it comes to the diagnosis and treatment planning of orthodontic cases.

*“When treatment **planning** a new case, in my head I could see all the steps it would take from start to finish, sort of like **playing a slow motion movie**. However, I was limited with the mechanics using twin brackets. It was frustrating trying to get what I knew and could see in my head to actually happen at times, until I began using Empower 2 brackets. Immediately, it felt like **freedom**. The limitations I had faced for almost 20 years were gone and what was in my head was **finally possible** in my hands.”*

I take my time placing brackets very precisely at the initial bonding appointment, so I don't have to do many repositionings or wire bending down the road, saving chair time and extra appointments. Empower 2 does not claim to treat cases “faster” but in my experience it takes less appointments to finish cases, because teeth are free to unravel, arches widen easily (I actually use less palatal expanders now), and you can begin using power chain, open coil springs, and short elastics from the very beginning.

# MY RX: DR. SHADOW ASGARI

## BRACKETS: .018

Empower 2 — Roth Compatible U2-2, McLaughlin, Bennett, Trevisi\* on remainder of teeth  
Interactive U/L 3-3, Hooks on 3's  
Passive U/L 4, 5, Hooks on 4's and 5's  
iFit Molar Tubes on 6's and 7's  
LP Molar Tubes on U/L 6's and 7's

## WIRE

VLP Arch Form

Initial Alignment and Leveling

**.014 or .016 NiTi depending on crowding**

Early Torque Control & Lateral Development

**.016 x .016 NiTi followed by panoramic radiograph**

Finishing

**.016 x .022 Stainless Steel**

## TIPS, TRICKS, AND INSIGHTS

Because of longer appointment intervals, (8-10 weeks), I was eventually able to close an entire day down in my office each week. I went from 4 days to 3 days per week. Imagine the savings and talk about efficiency! This is an EFFICIENT and very clean system. My staff love this system because they can see dramatic results and changes from one appointment to the next, because we work smarter now not harder, and because its a more hygienic system versus rubber O-ties.

The transition from twin to Empower 2 was smooth, and I love being able to do more at the initial bonding appointment, such as starting short light elastics from the beginning. Some cases would come back 8-10 weeks later and look close to finished!

\* The American Orthodontics version of the McLaughlin, Bennett, Trevisi System does not claim to be a duplication of any other, nor does American Orthodontics imply they are endorsed in any way by Drs. McLaughlin, Bennett, or Trevisi.



## DR. TROY CHRISTENSEN

Dr. Christensen graduated from UNLV in 1995 with a Bachelor of Science degree in Biomechanical Kinesiology. During his time in undergraduate study, he took a two year hiatus from his studies to serve a service mission in the Dominican Republic. He attended dental school at Creighton University and graduated Magna Cum Laude in 2000. While at Creighton he received numerous academic awards and distinctions, including memberships into the prestigious Alpha Omega International Dental Fraternity and Omricon Kappa Upsilon National Dental Honor Society, as well as membership into Alpha Sigma Nu, the National Jesuit Honor Society. He received his MS degree and certificate in Orthodontics from Baylor College of Dentistry in 2002.

***“Educate your patients about the advantages of Empower 2 and Dual Activation. They will be pleasantly surprised with the comfort and beautiful finish.”***

When I was using a fully passive system, I enjoyed the lower ligation friction and efficient initial results that I experienced. However, I missed the greater control I was used to with twin brackets. The Dual Activation of Empower 2 combines the best of both worlds giving me more efficient, accurate control on anterior teeth, coupled with the lower ligation friction benefits on passive posteriors.

In my experience, the Dual Activation of Empower 2 provides:

- Reduced ligation friction throughout the system compared to twin brackets, allowing me to provide my patients more efficient and comfortable treatment.
- Earlier and increased torque control of incisors and canines.
- Better arch form development, buccal uprighting, and minimal wire bending in the posterior.
- Easier extension of treatment intervals, which not only gives wires time to work, but also pleases patients and parents.

# MY RX: DR. TROY CHRISTENSEN

## BRACKETS: .022

Empower 2 — Andrews Compatible U2-2, McLaughlin, Bennett, Trevisi\* on Remainder of Teeth  
Interactive U/L 3-3, Hooks on 3's  
Passive U/L 4, 5, Hooks on 4's, 5's  
iFit Molar Tubes on U/L 6's and 7's

## WIRE

VLP Arch Form

Initial Alignment and Leveling

**.014 NT3<sup>®</sup> NiTi and .018 NT3, both with Pre-Loaded Stops**

Early Torque Control & Lateral Development

**.020 x .020 NT3 NiTi**

Finishing

**.016 x .022 Stainless Steel Upper**

**.016 x .022 Stainless Steel Lower**

## TIPS, TRICKS, AND INSIGHTS

I don't keep separate inventories of high or low torque brackets – if I need additional torque, I add it to the wire.

Because Empower brackets express the torque built into the prescription, I switched from higher to lower positive torque values on upper 2-2 to avoid excessive labial crown torque.

Patience – I trust the prescription and my bracket positioning. I get to my .020 x .020 wire and leave it for 8-10 weeks.

I take a wax impression of the lower arch after the .020 x .020 wire. I coordinate both finishing wires to this arch form. I use a symmetry template to verify arch form accuracy and consistency and re-coordinate the finishing wires as needed.

\* The American Orthodontics version of the McLaughlin, Bennett, Trevisi System does not claim to be a duplication of any other, nor does American Orthodontics imply they are endorsed in any way by Drs. McLaughlin, Bennett, or Trevisi.



## DR. BRIAN SCOTT

In 2010, Dr. Brian Scott assumed the practice of his father and continues the family tradition of providing patients with exceptional orthodontic care. Dr. Scott attended the University of Southern Colorado for his undergraduate studies in biology and earned his dental degree, with honors, from The Creighton University School of Dentistry. He completed his specialty training in orthodontics and received a master's degree from the Detroit Mercy School of Dentistry.

Additionally, Dr. Scott completed an intensive two-year post graduate course at the Advanced Education in Orthodontics Institute, considered the most advanced course of its type in the world, teaching the Roth-Williams philosophy of orthodontics. He has been recognized by his peers as the Top Orthodontist in Pueblo, Colorado each year since 2013 by 5280 Magazine in Denver.

Dr. Scott is currently a member of the American Association of Orthodontists, Colorado Association of Orthodontists, Rocky Mountain Society of Orthodontists, American Dental Association, Southeastern Colorado Dental Association and the Southeastern Colorado Dental Study Club.

*“The transition to Empower 2 Brackets and American Orthodontics in 2018 was as **seamless** as I could have hoped for with **no disruption** to my practice or, more importantly, **my patients.**”*

I started out using a fully interactive Roth system until 2014 when I learned about the CCO Rx. I preferred the lighter tip and torque values, especially in the cuspids and the posterior. I liked the more natural finish of the CCO Rx and I experienced less overcorrection than with the Roth prescription.

The transition to fully interactive Empower 2 system in 2018 using the modified CCO Rx has been completely seamless, allowing me to continue to provide the most efficient service to my patients. It's important to me that my brackets are made in America and knowing I can rely on the dependability of service and delivery from American Orthodontics.



# MY RX: DR. BRIAN SCOTT

## BRACKETS: .022

---

Empower 2 — CCO Compatible

Interactive U/L 5-5, Hooks on U/L 3's, 4's, and 5's

LP Molar Tubes on U/L 6's and 7's

## WIRE

---

Initial Alignment and Leveling

**Round NiTi (.012, .014 or .016 depending on crowding)**

Torque Control

**.020 x .020 Heat Activated Three Zone Wire**

Finishing

**.019 x .025 Stainless Steel Coordinated Arches**

**.016 x .025 Stainless Steel for Final Settling**

## TIPS, TRICKS, AND INSIGHTS

---

I finish in .019 x .025 stainless steel braided wire, which accepts bends well and allows the teeth to settle. By taking the brackets off the upper and lower posterior teeth from 3's to 7's roughly two to three weeks prior to debond, the posterior teeth can settle gently while maintaining the position of the anterior teeth with a segmented wire. The final debond appointment then only takes 40 minutes rather than 90 minutes. Plus, patients are happy that 75% of their brackets are taken off early.



## DR. PAOLO MANZO AND DR. CESARE LUZI

Dr. Manzo graduated cum laude in Dentistry (DDS) in 1997 and he completed his post-graduation in orthodontics (MSc) with honors at the University of Naples "Federico II". In 2007 he received a PhD in Oral Science at the Department of Orthodontics, University of Naples "Federico II". Dr. Manzo is certified by the Italian Board of Orthodontics (IBO) and an adjunct associate professor at the University of Naples "Federico II".

*"Low friction has brought **enormous advantages** to every straight-wire technique. Passive self-ligation has its focus points in reducing friction thereby **increasing efficiency** in the speed of leveling, alignment, and sliding mechanics. Yet, friction is **essential** for three-dimension control of tooth movement. **The Dual Activation System**, featuring active characteristics on the anterior brackets while at the same time posterior passive characteristics, gives us the opportunity of achieving **precise incisor torque control and detailed finishing results, without losing** the benefits of low friction in the side segments."*



Dr. Cesare Luzi graduated with honors in Dentistry and Dental Prosthetics at the University of Rome "La Sapienza" in 2000 and earned the Specialty in Orthodontics at the Department of Orthodontics of the University of Aarhus, Denmark. Dr. Luzi is founder and first President of EPSOS (European Society of Orthodontic Specialists). He is active in many professional organizations and the author of numerous publications in the orthodontic field and speaker at national and international conferences and congresses.

# OUR RX: DR. PAOLO MANZO AND DR. CESARE LUZI

## BRACKETS: .022

Empower 2 — McLaughlin, Bennett, Trevisi\*

Interactive U/L 3-3, Hooks on 3's

Passive U/L 4's, 5's

Molar Tubes U 6's, 7's and L 7's

Empower 2 Double L 6's

\* The American Orthodontics version of the McLaughlin, Bennett, Trevisi System does not claim to be a duplication of any other, nor does American Orthodontics imply they are endorsed in any way by Drs. McLaughlin, Bennett, or Trevisi.

## WIRE

Form I or Form III

Alignment, Leveling and Early Torque Control

**.014 Tanzo Mid-Force with Pre-Loaded Stops**

**.014 x .025 Tanzo Mid-Force with Pre-Loaded Stops**

Working Phase

**.019 x .025 Tanzo Mid-Force with Pre-Loaded Stops**

**.019 x .025 Stainless Steel Posted**

Finishing

**.018 x .025 Stainless Steel Coax**

Retention

**Upper Hawley Plate**

**Lower .0195 Stainless Steel Coax**

## TIPS, TRICKS, AND INSIGHTS

In cases of severe deep bite an .019 x .025 Tanzo Midforce Reverse Curve is a good choice and leave it working at least 3-4 months. An .018 Australian wire can be added before the .019 x .025 Tanzo Midforce Reverse Curve or, combined with .019 x .025 Tanzo, can be inserted in the lower auxiliary slot of the molar tube and overlayed on the basic wire to improve the deep bite correction. This phase of patient control should last no longer than 6-8 weeks.

For hyperdivergent patients, try to include bite blocks for the vertical control of the molars particularly during the elastics phase and during Spee Curve correction.

If preferred, an .0195 Stainless Steel Coax on the upper arch can be used instead of a .018 x .025 Stainless Steel for finishing in the cases with final lateral (canines and bicuspids) increased overjet. It is easier to optimize the lateral overjet with a round wire.



## DR. GUIDO SAMPERMANS

Dr. Guido Sampermans graduated in 1980 as a general dentist from the University of Leuven, Belgium. In 1986, he started his private orthodontic office in Belgium and in 1997 an office in Heinsberg, Germany. From 2003 to 2010, he led an orthodontic office in Maastricht, the Netherlands. In 2010 he opened a new office in Echt, the Netherlands. He currently is working and teaching in Vienna, Austria.

Dr. Sampermans was an affiliate member of the Angle Society in Southern California (USA) and has taught orthodontic treatment philosophy and orthodontic practice management both inside and outside of Europe for more than 20 years. He also offers micro-seminars in his office on self ligating brackets, indirect bonding, computer related 3D technology, and modern practice management. Since 2003, he has spoken at 50 orthodontic congresses. Dr. Sampermans has first-class knowledge and

extensive experience with pre-adjusted appliance systems (Andrews, Roth, MBT, Roncone). He has worked with active self ligating bracket systems since 2003, finishing over 7500 cases with this system.

*"I have worked with active self ligating brackets since 2003. The **savings** in chair time pays for the increase in cost of an SL bracket over a traditionally ligated twin bracket. The other reason **I prefer active self ligating brackets** is the **excellent torque control** of the active clips. The correct inclination of all the teeth is a very important issue for the **post treatment stability** and is by far the most difficult orthodontic movement to achieve. The torque control of the active clips of the Empower 2 brackets is excellent. I finish most cases with straight wire, without finishing bends for torque control."*

# MY RX: DR. GUIDO SAMPERMANS

## BRACKETS: .022

Empower 2 — Metal and Clear McLaughlin, Bennett, Trevisi\* Compatible - Modified Roncone\*  
Interactive U/L 5-5, Hooks on U/L 3's, 4's, and 5's  
LP Molar Tubes on 6's and 7's

## WIRE

Arch Form VLP

Initial Alignment and Leveling

**.014 Tanzo (.013 Tanzo if Crowded)**

**.018 Tanzo**

Space Opening and Class III (Lower Arch)

**.020 Stainless Steel**

Torque Control

**.020 x .020 Tanzo**

Finishing and Space Closure

**.019 x .025 Stainless Steel**

**.019 x .025 Beta - Ti (Space Closure with Loops)**

## TIPS, TRICKS, AND INSIGHTS

Use high torque brackets for the upper incisors in almost all cases. A primary complaint of my orthognatic surgeon is when patients are orthodontically prepared for surgery with standing upper incisors which are too upright. High torque prescription combined with active self ligating brackets produces correct incisor torque even with an .019 x .025 straight wire.

Using superelastic wires completely changed my extraction planning by using the binding effect of these wires for opening spaces and correcting midlines. In asymmetric cases, I often extract to simplify cases and create less need for anchorage. Anchorage does not always require a TAD. There are many ways to increase or loosen anchorage without a screw.

Retract upper incisors with loop mechanics. I bring upper canines in a Class I relation as soon as possible, very often away from the lateral incisors. Last treatment step is to retract the upper incisors. Loop mechanics is the simplest way to do this.

\* The American Orthodontics version of the McLaughlin, Bennett, Trevisi System does not claim to be a duplication of any other, nor does American Orthodontics imply they are endorsed in any way by Drs. McLaughlin, Bennett, Trevisi, or Roncone.

## MCLAUGHLIN, BENNETT, TREVISI\* SYSTEM

		Torq	Ang	R/L	INTERACTIVE .018		INTERACTIVE .022		PASSIVE .022	
					No Hook	With Hook	No Hook	With Hook	No Hook	With Hook
					<b>MAXILLARY</b>	Central	+17	+4	R L	1475-18-1117 1475-18-2117
Lateral	+10	+8	R L	1475-18-1210 1475-18-2210			1485-22-1210 1485-22-2210			
Cuspid	0	+8	R L			1475-18-130HD 1475-18-230HD		1485-22-130HD 1485-22-230HD		1585-22-130HD 1585-22-230HD
1st and 2nd Bicuspid	-7	0	R L	1475-18-1407 1475-18-2407		1475-18-1407HD 1475-18-2407HD	1485-22-1407 1485-22-2407	1485-22-1407HD 1485-22-2407HD	1585-22-1407 1585-22-2407	1585-22-1407HD 1585-22-2407HD
<b>MANDIBULAR</b>	Anteriors	-6	0	R L	1475-18-4106 1475-18-3106		1485-22-4106 1485-22-3106			
	Cuspid	0	+3	R L		1475-18-430HD 1475-18-330HD		1485-22-430HD 1485-22-330HD		1585-22-430HD 1585-22-330HD
	1st Bicuspid	-12	+2	R L	1475-18-4412 1475-18-3412	1475-18-4412HD 1475-18-3412HD	1485-22-4412 1485-22-3412	1485-22-4412HD 1485-22-3412HD		
	2nd Bicuspid	-17	+2	R L	1475-18-4517 1475-18-3517	1475-18-4517HD 1475-18-3517HD	1485-22-4517 1485-22-3517	1485-22-4517HD 1485-22-3517HD		

Note: All Empower Clear hooks are distal

## COMPATIBLE WITH A ROTH\* SYSTEM

		Torq	Ang	R/L	INTERACTIVE .018		INTERACTIVE .022	
					No Hook	With Hook	No Hook	With Hook
<b>MAXILLARY</b>	Central	+12	+5	R L	1475-18-1112 1475-18-2112		1485-22-1112 1485-22-2112	
	Lateral	+8	+9	R L	1475-18-128 1475-18-228		1485-22-128 1485-22-228	
	Cuspid	-2	+9	R L		1475-18-1302HD 1475-18-2302HD		1485-22-1302HD 1485-22-2302HD
	1st and 2nd Bicuspid	-7	0	R L	1475-18-1407 1475-18-2407	1475-18-1407HD 1475-18-2407HD	1485-22-1407 1485-22-2407	1485-22-1407HD 1485-22-2407HD
<b>MANDIBULAR</b>	Anteriors	-1	0	R L	1475-18-4101 1475-18-3101		1485-22-4101 1485-22-3101	
	Cuspid	-11	+7	R L		1475-18-4311HD 1475-18-3311HD		1485-22-4311HD 1485-22-3311HD
	1st Bicuspid	-17	0	R L	1475-18-4417 1475-18-3417	1475-18-4417HD 1475-18-3417HD	1485-22-4417 1485-22-3417	1485-22-4417HD 1485-22-3417HD
	2nd Bicuspid	-22	0	R L	1475-18-4522 1475-18-3522	1475-18-4522HD 1475-18-3522HD	1485-22-4522 1485-22-3522	1485-22-4522HD 1485-22-3522HD

Note: All Empower Clear hooks are distal

### Empower 2 Clear Bracket Identification

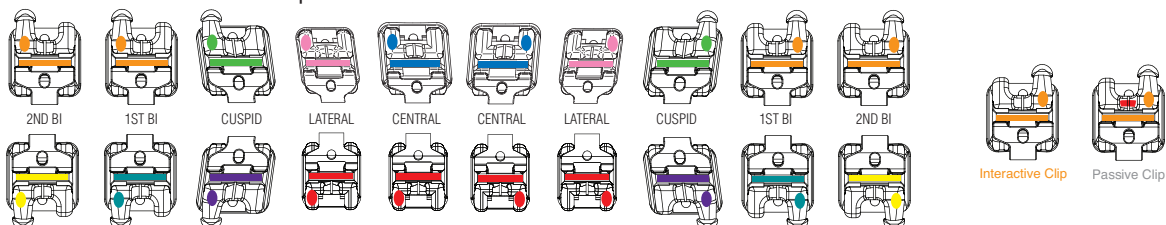

## COMPATIBLE WITH THE CCO<sup>\*</sup> SYSTEM

		Torq	Ang	R/L	INTERACTIVE .018		INTERACTIVE .022		PASSIVE .022	
					No Hook	With Hook	No Hook	With Hook	No Hook	With Hook
MAXILLARY	Central	+12	+5	R L	1475-18-1112 1475-18-2112		1485-22-1112 1485-22-2112			
	Lateral	+10	+8	R L	1475-18-1210 1475-18-2210		1485-22-1210 1485-22-2210			
	Cuspid	0	+8	R L		1475-18-130HD 1475-18-230HD		1485-22-130HD 1485-22-230HD		1585-22-130HD 1585-22-230HD
	1st and 2nd Bicuspid	-7	0	R L	1475-18-1407 1475-18-2407	1475-18-1407HD 1475-18-2407HD	1485-22-1407 1485-22-2407	1485-22-1407HD 1485-22-2407HD	1585-22-1407 1585-22-2407	1585-22-1407HD 1585-22-2407HD
MANDIBULAR	Anteriors	-6	0	R L	1475-18-4106 1475-18-3106		1485-22-4106 1485-22-3106			
	Cuspid	0	+3	R L		1475-18-430HD 1475-18-330HD		1485-22-430HD 1485-22-330HD		1585-22-430HD 1585-22-330HD
	1st Bicuspid	-12	+2	R L	1475-18-4412 1475-18-3412	1475-18-4412HD 1475-18-3412HD	1485-22-4412 1485-22-3412	1485-22-4412HD 1485-22-3412HD		
	2nd Bicuspid	-17	+2	R L	1475-18-4517 1475-18-3517	1475-18-4517HD 1475-18-3517HD	1485-22-4517 1485-22-3517	1485-22-4517HD 1485-22-3517HD		

Note: All Empower Clear hooks are distal

## EMPOWER 2 CLEAR OPTIONS

MAXILLARY	Torq	Ang	R/L	INTERACTIVE .022	
				No Hook	With Hook
1st and 2nd Bicuspid	-12	+2	R L	1485-22-1412 1485-22-2412	
MANDIBULAR					
Cuspid	-2	+9	R L		1485-22-4302HD 1485-22-3302HD
1st Bicuspid	-7	0	R L		1485-22-4407HD 1485-22-3407HD
2nd Bicuspid	-12	+2	R L		1485-22-4512HD 1485-22-3512HD

Note: All Empower Clear hooks are distal

## EMPOWER 2 CLEAR INDIVIDUAL PATIENT SETUPS U/L 5-5

McLaughlin, Bennett, Trevisi*	INTERACTIVE .018	INTERACTIVE .022
Hooks on Cuspids		126-029933
Hooks on Cuspids, 1st & 2nd Bicuspids	126-029930	126-029934
<b>Compatible with Roth*</b>		
Hooks on Cuspids		126-029935
Hooks on Cuspids, 1st & 2nd Bicuspids	126-029932	126-029936

Note: All Empower Clear hooks are distal

\* American Orthodontics' prescription versions. No endorsement by the doctor(s) is implied. CCO is a registered trademark of Dentsply Sirona.

\* See your Sales Representative for Empower 2 Clear prescription availability

## MCLAUGHLIN, BENNETT, TREVISI\* SYSTEM

	Torq	Ang	R/L	INTERACTIVE				PASSIVE				
				.018		.022		.018		.022		
				No Hook	With Hook	No Hook	With Hook	No Hook	With Hook	No Hook	With Hook	
MAXILLARY	Central	+17	+4	R	475-1117 475-2117		485-1117 485-2117			585-1117 585-2117		
	Lateral	+10	+8	R	475-1210 475-2210	475-1210B 475-2210B	485-1210 485-2210	485-1210B 485-2210B		585-1210 585-2210		
	Cuspid	0	+8	R		475-130B 475-230B	485-130 485-230	485-130B 485-230B		575-130B 575-230B	585-130 585-230	585-130B 585-230B
		-7	+8	R		475-1307B 475-2307B		485-1307B 485-2307B		575-1307B 575-2307B		585-1307B 585-2307B
	1st and 2nd Bicuspid Standard Pad	-7	0	R	475-1407 475-2407	475-1407B 475-2407B	485-1407 485-2407	485-1407B 485-2407B	575-1407 575-2407	575-1407B 575-2407B	585-1407 585-2407	585-1407B 585-2407B
	True Offset	-7	0	R	475-71407 475-72407	475-71407B 475-72407B	485-71407 485-72407	485-71407B 485-72407B	575-71407 575-72407	575-71407B 575-72407B	585-71407 585-72407	585-71407B 585-72407B
	Extended Pad	-7	0	R	475-81407 475-82407	475-81407B 475-82407B	485-81407 485-82407	485-81407B 485-82407B	575-81407 575-82407	575-81407B 575-82407B	585-81407 585-82407	585-81407B 585-82407B
	BX Pad	-7	0	R	475-18-91407 475-18-92407	475-18-91407HD 475-18-92407HD	485-22-91407 485-22-92407	485-22-91407HD 485-22-92407HD	575-18-91407 575-18-92407	575-18-91407HD 575-18-92407HD	585-22-91407 585-22-92407	585-22-91407HD 585-22-92407HD
MANDIBULAR	Anteriors	-6	0	R	475-4106 475-3106	475-4106B 475-3106B	485-4106 485-3106	485-4106B 485-3106B			585-4106 585-3106	
		-1	0	R	475-4101 475-3101	475-4101B 475-3101B	485-4101 485-3101	485-4101B 485-3101B			585-4101 585-3101	
	Cuspid	0	+3	R	475-430 475-330	475-430B 475-330B	485-430 485-330	485-430B 485-330B		575-430B 575-330B	585-430 585-330	585-430B 585-330B
		-6	+3	R	475-4306 475-3306	475-4306B 475-3306B	485-4306 485-3306	485-4306B 485-3306B		575-4306B 575-3306B		585-4306B 585-3306B
	1st Bicuspid Standard Pad	-12	+2	R	475-4412 475-3412	475-4412B 475-3412B	485-4412 485-3412	485-4412B 485-3412B	575-4412 575-3412	575-4412B 575-3412B	585-4412 585-3412	585-4412B 585-3412B
	True Offset	-12	+2	R	475-74412 475-73412	475-74412B 475-73412B	485-74412 485-73412	485-74412B 485-73412B	575-74412 575-73412	575-74412B 575-73412B	585-74412 585-73412	585-74412B 585-73412B
	Extended Pad	-12	+2	R	475-84412 475-83412	475-84412B 475-83412B	485-84412 485-83412	485-84412B 485-83412B	575-84412 575-83412	575-84412B 575-83412B	585-84412 585-83412	585-84412B 585-83412B
	BX Pad	-12	+2	R	475-18-94412 475-18-93412	475-18-94412HD 475-18-93412HD	485-22-94412 485-22-93412	485-22-94412HD 485-22-93412HD	575-18-94412 575-18-93412	575-18-94412HD 575-18-93412HD	585-22-94412 585-22-93412	585-22-94412HD 585-22-93412HD
	2nd Bicuspid Standard Pad	-17	+2	R	475-4517 475-3517	475-4517B 475-3517B	485-4517 485-3517	485-4517B 485-3517B	575-4517 575-3517	575-4517B 575-3517B	585-4517 585-3517	585-4517B 585-3517B
	True Offset	-17	+2	R	475-74517 475-73517	475-74517B 475-73517B	485-74517 485-73517	485-74517B 485-73517B	575-74517 575-73517	575-74517B 575-73517B	585-74517 585-73517	585-74517B 585-73517B
	Extended Pad	-17	+2	R	475-84517 475-83517	475-84517B 475-83517B	485-84517 485-83517	485-84517B 485-83517B	575-84517 575-83517	575-84517B 575-83517B	585-84517 585-83517	585-84517B 585-83517B
	BX Pad	-17	+2	R	475-18-94517 475-18-93517	475-18-94517HD 475-18-93517HD	485-22-94517 485-22-93517	485-22-94517HD 485-22-93517HD	575-18-94517 575-18-93517	575-18-94517HD 575-18-93517HD	585-22-94517 585-22-93517	585-22-94517HD 585-22-93517HD

Note: All Empower 2 bracket hooks are distal



## COMPATIBLE WITH A ROTH\* SYSTEM

	Torq	Ang	R/L	INTERACTIVE				PASSIVE				
				.018		.022		.018		.022		
				No Hook	With Hook	No Hook	With Hook	No Hook	With Hook	No Hook	With Hook	
MAXILLARY	Central	+12	+5	R	475-1112 475-2112		485-1112 485-2112			585-1112 585-2112		
	Lateral	+8	+9	R	475-128 475-228	475-128B 475-228B	485-128 485-228	485-128B 485-228B		585-128 585-228		
	Cuspid	-2	+9	R	475-1302 475-2302	475-1302B 475-2302B	485-1302 485-2302	485-1302B 485-2302B	575-1302B 575-2302B		585-1302B 585-2302B	
				L		475-1302AB 475-2302AB		485-1302AB 485-2302AB			585-1302AB 585-2302AB	
	1st and 2nd Bicuspid Standard Pad	-7	0	R	475-1407 475-2407	475-1407B 475-2407B	485-1407 485-2407	485-1407B 485-2407B	575-1407 575-2407	575-1407B 575-2407B	585-1407 585-2407	585-1407B 585-2407B
	True Offset	-7	0	R	475-71407 475-72407	475-71407B 475-72407B	485-71407 485-72407	485-71407B 485-72407B	575-71407 575-72407	575-71407B 575-72407B	585-71407 585-72407	585-71407B 585-72407B
	Extended Pad	-7	0	R	475-81407 475-82407	475-81407B 475-82407B	485-81407 485-82407	485-81407B 485-82407B	575-81407 575-82407	575-81407B 575-82407B	585-81407 585-82407	585-81407B 585-82407B
	BX Pad	-7	0	R	475-18-91407 475-18-92407	475-18-91407HD 475-18-92407HD	485-22-91407 485-22-92407	485-22-91407HD 485-22-92407HD	575-18-91407 575-18-92407	575-18-91407HD 575-18-92407HD	585-22-91407 585-22-92407	585-22-91407HD 585-22-92407HD
MANDIBULAR	Anteriors	-1	0	R	475-4101 475-3101	475-4101B 475-3101B	485-4101 485-3101	485-4101B 485-3101B			585-4101 585-3101	
	Cuspid	-11	+7	R	475-4311 475-3311	475-4311B 475-3311B	485-4311 485-3311	485-4311B 485-3311B	575-4311B 575-3311B		585-4311B 585-3311B	
	1st Bicuspid Standard Pad	-17	0	R	475-4417 475-3417	475-4417B 475-3417B	485-4417 485-3417	485-4417B 485-3417B	575-4417 575-3417	575-4417B 575-3417B	585-4417 585-3417	585-4417B 585-3417B
	True Offset	-17	0	R	475-74417 475-73417	475-74417B 475-73417B	485-74417 485-73417	485-74417B 485-73417B	575-74417 575-73417	575-74417B 575-73417B	585-74417 585-73417	585-74417B 585-73417B
	Extended Pad	-17	0	R	475-84417 475-83417	475-84417B 475-83417B	485-84417 485-83417	485-84417B 485-83417B	575-84417 575-83417	575-84417B 575-83417B	585-84417 585-83417	585-84417B 585-83417B
	BX Pad	-17	0	R	475-18-94417 475-18-93417	475-18-94417HD 475-18-93417HD	485-22-94417 485-22-93417	485-22-94417HD 485-22-93417HD	575-18-94417 575-18-93417	575-18-94417HD 575-18-93417HD	585-22-94417 585-22-93417	585-22-94417HD 585-22-93417HD
	2nd Bicuspid Standard Pad	-22	0	R	475-4522 475-3522	475-4522B 475-3522B	485-4522 485-3522	485-4522B 485-3522B	575-4522 575-3522	575-4522B 575-3522B	585-4522 585-3522	585-4522B 585-3522B
	True Offset	-22	0	R	475-74522 475-73522	475-74522B 475-73522B	485-74522 485-73522	485-74522B 485-73522B	575-74522 575-73522	575-74522B 575-73522B	585-74522 585-73522	585-74522B 585-73522B
	Extended Pad	-22	0	R	475-84522 475-83522	475-84522B 475-83522B	485-84522 485-83522	485-84522B 485-83522B	575-84522 575-83522	575-84522B 575-83522B	585-84522 585-83522	585-84522B 585-83522B
	BX Pad	-22	0	R	475-18-94522 475-18-93522	475-18-94522HD 475-18-93522HD	485-22-94522 485-22-93522	485-22-94522HD 485-22-93522HD	575-18-94522 575-18-93522	575-18-94522HD 575-18-93522HD	585-22-94522 585-22-93522	585-22-94522HD 585-22-93522HD

Note: All Empower 2 bracket hooks are distal

### Empower 2 Metal Bracket Identification

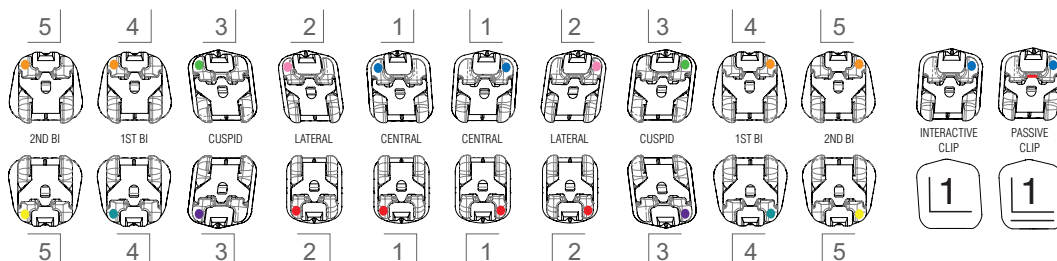

Palmer notation is laser marked on the pads for ease of bracket identification and organization

## MODIFIED DAMON\* SYSTEM

	Torq	Ang	R/L	INTERACTIVE				PASSIVE				
				.018		.022		.018		.022		
				No Hook	With Hook	No Hook	With Hook	No Hook	With Hook	No Hook	With Hook	
MAXILLARY	Central High Torque**	+22	+5	R	475-1122 475-2122		485-1122 485-2122				585-1122 585-2122	
	Standard Torque	+17	+4	R	475-1117 475-2117		485-1117 485-2117				585-1117 585-2117	
	Low Torque**	+7	+4	R	475-117 475-217		485-117 485-217				585-117 585-217	
	Lateral High Torque**	+14	+8	R	475-1214 475-2214		485-1214 485-2214				585-1214 585-2214	
	Standard Torque	+8	+9	R	475-128 475-228	475-128B 475-228B	485-128 485-228	485-128B 485-228B			585-128 585-228	
	Low Torque**	+3	+8	R	475-123 475-223		485-123 485-223	485-123B 485-223B			585-123 585-223	
	Cuspid Standard Torque	+7	+5	R		475-137B 475-237B		485-137B 485-237B			585-137B 585-237B	
	Low Torque**	0	+8	R		475-130B 475-230B	485-130 485-230	485-130B 485-230B	575-130B 575-230B	585-130 585-230	585-130B 585-230B	
	1st and 2nd Bicuspid Standard Pad	-12	+2	R	475-1412 475-2412		485-1412 485-2412	485-1412B 485-2412B	575-1412 575-2412		585-1412 585-2412	585-1412B 585-2412B
	True Offset	-12	+2	R			485-71412 485-72412	485-71412B 485-72412B			585-71412B 585-72412B	
	Extended Pad	-12	+2	R			485-81412 485-82412				585-81412 585-82412	
	BX Pad	-12	+2	R			485-22-91412 485-22-92412	485-22-91412HD 485-22-92412HD			585-22-91412 585-22-92412	585-22-91412HD 585-22-92412HD
	MANDIBULAR	Anteriors Standard Torque	-1	0	R	475-4101 475-3101	475-4101B 475-3101B	485-4101 485-3101	485-4101B 485-3101B			585-4101 585-3101
		Low Torque**	-6	0	R	475-4106 475-3106	475-4106B 475-3106B	485-4106 485-3106	485-4106B 485-3106B			585-4106 585-3106
Cuspid Standard Torque		+7	+5	R		475-437B 475-337B		485-437B 485-337B			585-437 585-337	585-437B 585-337B
Low Torque**		0	+3	R	475-430 475-330	475-430B 475-330B	485-430 485-330	485-430B 485-330B	575-430B 575-330B	585-430 585-330	585-430B 585-330B	
1st Bicuspid		-12	+2	R	475-4412 475-3412	475-4412B 475-3412B	485-4412 485-3412	485-4412B 485-3412B	575-4412 575-3412	575-4412B 575-3412B	585-4412 585-3412	585-4412B 585-3412B
True Offset		-12	+2	R	475-74412 475-73412	475-74412B 475-73412B	485-74412 485-73412	485-74412B 485-73412B	575-74412 575-73412	575-74412B 575-73412B	585-74412 585-73412	585-74412B 585-73412B
Extended Pad		-12	+2	R	475-84412 475-83412	475-84412B 475-83412B	485-84412 485-83412	485-84412B 485-83412B	575-84412 575-83412	575-84412B 575-83412B	585-84412 585-83412	585-84412B 585-83412B
BX Pad		-12	+2	R	475-18-94412 475-18-93412	475-18-94412HD 475-18-93412HD	485-22-94412 485-22-93412	485-22-94412HD 485-22-93412HD	575-18-94412 575-18-93412	575-18-94412HD 575-18-93412HD	585-22-94412 585-22-93412	585-22-94412HD 585-22-93412HD
2nd Bicuspid		-17	+2	R	475-4517 475-3517	475-4517B 475-3517B	485-4517 485-3517	485-4517B 485-3517B	575-4517 575-3517	575-4517B 575-3517B	585-4517 585-3517	585-4517B 585-3517B
True Offset		-17	+2	R	475-74517 475-73517	475-74517B 475-73517B	485-74517 485-73517	485-74517B 485-73517B	575-74517 575-73517	575-74517B 575-73517B	585-74517 585-73517	585-74517B 585-73517B
Extended Pad		-17	+2	R	475-84517 475-83517	475-84517B 475-83517B	485-84517 485-83517	485-84517B 485-83517B	575-84517 575-83517	575-84517B 575-83517B	585-84517 585-83517	585-84517B 585-83517B
BX Pad		-17	+2	R	475-18-94517 475-18-93517	475-18-94517HD 475-18-93517HD	485-22-94517 485-22-93517	485-22-94517HD 485-22-93517HD	575-18-94517 575-18-93517	575-18-94517HD 575-18-93517HD	585-22-94517 585-22-93517	585-22-94517HD 585-22-93517HD

Note: All Empower 2 bracket hooks are distal

\*\* Upon request, high torque passive brackets can be marked with an additional red color dot; low torque passive can be marked with green

## COMPATIBLE WITH THE CCO\* SYSTEM

	Torq	Ang	R/L	INTERACTIVE				PASSIVE					
				.018		.022		.018		.022			
				No Hook	With Hook	No Hook	With Hook	No Hook	With Hook	No Hook	With Hook		
MAXILLARY	Central	+12	+5	R	475-1112 475-2112		485-1112 485-2112			585-1112 585-2112			
	Low Torque**	+7	+4	R	475-117 475-217		485-117 485-217			585-117 585-217			
	Lateral	+10	+8	R	475-1210 475-2210	475-1210B 475-2210B	485-1210 485-2210	485-1210B 485-2210B		585-1210 585-2210			
	Low Torque**	+3	+8	R	475-123 475-223		485-123 485-223	485-123B 485-223B		585-123 585-223			
	Cuspid	0	+8	R		475-130B 475-230B	485-130 485-230	485-130B 485-230B	575-130B 575-230B	585-130 585-230	585-130B 585-230B		
		-7	+8	R		475-1307B 475-2307B		485-1307B 485-2307B	575-1307B 575-2307B		585-1307B 585-2307B		
	1st and 2nd Bicuspid Standard Pad	-7	0	R	475-1407 475-2407	475-1407B 475-2407B	485-1407 485-2407	485-1407B 485-2407B	575-1407 575-2407	575-1407B 575-2407B	585-1407 585-2407	585-1407B 585-2407B	
	True Offset	-7	0	R	475-71407 475-72407	475-71407B 475-72407B	485-71407 485-72407	485-71407B 485-72407B	575-71407 575-72407	575-71407B 575-72407B	585-71407 585-72407	585-71407B 585-72407B	
	Extended Pad	-7	0	R	475-81407 475-82407	475-81407B 475-82407B	485-81407 485-82407	485-81407B 485-82407B	575-81407 575-82407	575-81407B 575-82407B	585-81407 585-82407	585-81407B 585-82407B	
	BX Pad	-7	0	R	475-18-91407 475-18-92407	475-18-91407HD 475-18-92407HD	485-22-91407 485-22-92407	485-22-91407HD 485-22-92407HD	575-18-91407 575-18-92407	575-18-91407HD 575-18-92407HD	585-22-91407 585-22-92407	585-22-91407HD 585-22-92407HD	
	MANDIBULAR	Anteriors	-6	0	R	475-4106 475-3106	475-4106B 475-3106B	485-4106 485-3106	485-4106B 485-3106B			585-4106 585-3106	
			-1	0	R	475-4101 475-3101	475-4101B 475-3101B	485-4101 485-3101	485-4101B 485-3101B			585-4101 585-3101	
Cuspid		0	+3	R	475-430 475-330	475-430B 475-330B	485-430 485-330	485-430B 485-330B	575-430B 575-330B	585-430 585-330	585-430B 585-330B		
		-6	+3	R	475-4306 475-3306	475-4306B 475-3306B		485-4306B 485-3306B	575-4306B 575-3306B		585-4306B 585-3306B		
1st Bicuspid Standard Pad		-12	+2	R	475-4412 475-3412	475-4412B 475-3412B	485-4412 485-3412	485-4412B 485-3412B	575-4412 575-3412	575-4412B 575-3412B	585-4412 585-3412	585-4412B 585-3412B	
True Offset		-12	+2	R	475-74412 475-73412	475-74412B 475-73412B	485-74412 485-73412	485-74412B 485-73412B	575-74412 575-73412	575-74412B 575-73412B	585-74412 585-73412	585-74412B 585-73412B	
Extended Pad		-12	+2	R	475-84412 475-83412	475-84412B 475-83412B	485-84412 485-83412	485-84412B 485-83412B	575-84412 575-83412	575-84412B 575-83412B	585-84412 585-83412	585-84412B 585-83412B	
BX Pad		-12	+2	R	475-18-94412 475-18-93412	475-18-94412HD 475-18-93412HD	485-22-94412 485-22-93412	485-22-94412HD 485-22-93412HD	575-18-94412 575-18-93412	575-18-94412HD 575-18-93412HD	585-22-94412 585-22-93412	585-22-94412HD 585-22-93412HD	
2nd Bicuspid Standard Pad		-17	+2	R	475-4517 475-3517	475-4517B 475-3517B	485-4517 485-3517	485-4517B 485-3517B	575-4517 575-3517	575-4517B 575-3517B	585-4517 585-3517	585-4517B 585-3517B	
True Offset		-17	+2	R	475-74517 475-73517	475-74517B 475-73517B	485-74517 485-73517	485-74517B 485-73517B	575-74517 575-73517	575-74517B 575-73517B	585-74517 585-73517	585-74517B 585-73517B	
Extended Pad		-17	+2	R	475-84517 475-83517	475-84517B 475-83517B	485-84517 485-83517	485-84517B 485-83517B	575-84517 575-83517	575-84517B 575-83517B	585-84517 585-83517	585-84517B 585-83517B	
BX Pad		-17	+2	R	475-18-94517 475-18-93517	475-18-94517HD 475-18-93517HD	485-22-94517 485-22-93517	485-22-94517HD 485-22-93517HD	575-18-94517 575-18-93517	575-18-94517HD 575-18-93517HD	585-22-94517 585-22-93517	585-22-94517HD 585-22-93517HD	

Note: All Empower 2 bracket hooks are distal

\* American Orthodontics' prescription versions. No endorsement by the doctor(s) is implied. CCO is a Registered trademark of Dentsply Sirona.

\*\* Upon request, low torque passive brackets can be marked with an additional green color dot.

## MODIFIED RONCONE\* SYSTEM

					INTERACTIVE .022		PASSIVE .022	
					No Hook	With Hook	No Hook	With Hook
					Torq	Ang	R/L	
MAXILLARY	Central	+17	+4	R L	485-1117 485-2117		585-1117 585-2117	
	Lateral	+10	+8	R L	485-1210 485-2210	485-1210B 485-2210B	585-1210 585-2210	
	Cuspid	0	+8	R L	485-130 485-230	485-130B 485-230B	585-130 585-230	585-130B 585-230B
	1st and 2nd Bicuspid Standard Pad	-12	+2	R L	485-1412 485-2412	485-1412B 485-2412B	585-1412 585-2412	585-1412B 585-2412B
	True Offset	-12	+2	R L	485-71412 485-72412	485-71412B 485-72412B		585-71412B 585-72412B
	Extended Pad	-12	+2	R L	485-81412 485-82412		585-81412 585-82412	
	BX Pad	-12	+2	R L	485-22-91412 485-22-92412	485-22-91412HD 485-22-92412HD	585-22-91412 585-22-92412	585-22-91412HD 585-22-92412HD
MANDIBULAR	Anteriors	-1	0	R L	485-4101 485-3101	485-4101B 485-3101B	585-4101 585-3101	
	Cuspid	-2	+9	R L		485-4302B 485-3302B		585-4302B 585-3302B
	1st and 2nd Bicuspid Standard Pad	-7	0	R L	485-4407 485-3407	485-4407B 485-3407B	585-4407 585-3407	585-4407B 585-3407B
	True Offset	-7	0	R L		485-74407B 485-73407B	585-74407 585-73407	585-74407B 585-73407B
	BX Pad	-7	0	R L	485-22-94407 485-22-93407	485-22-94407HD 485-22-93407HD	585-22-94407 585-22-93407	585-22-94407HD 585-22-93407HD

Note: All Empower 2 bracket hooks are distal

## EMPOWER 2 OPTIONS

					INTERACTIVE .018		INTERACTIVE .022		PASSIVE .022	
					No Hook	With Hook	No Hook	With Hook	No Hook	With Hook
					Torq	Ang	R/L			
MAXILLARY	Central	+7	+4	R L	475-117 475-217		485-117 485-217		585-117 585-217	
	Lateral	+3	+8	R L	475-123 475-223		485-123 485-223	485-123B 485-223B	585-123 585-223	
	Cuspid	+7	+5	R L		475-137B 475-237B		485-137B 485-237B		585-137B 585-237B
	1st and 2nd Bicuspid Extended Pad	-12	+2	R L			485-81412 485-82412		585-81412 585-82412	
MANDIBULAR	Cuspid	+7	+5	R L		475-437B 475-337B		485-437B 485-337B	585-437 585-337	585-437B 585-337B
	1st Bicuspid Extended Pad	-7	0	R L				485-84407B 485-83407B		
	2nd Bicuspid Extended Pad	-12	+2	R L				485-84512B 485-83512B		

Note: All Empower 2 bracket hooks are distal

## EMPOWER 2 INDIVIDUAL PATIENT SETUPS U/L 5-5

McLaughlin, Bennett, Trevisi	INTERACTIVE .018	INTERACTIVE .022	DUAL ACT .018	DUAL ACT .022
Hooks on Cuspids		126-029943		126-029948
Hooks on Cuspids, 1st & 2nd Bicuspids	126-029940	126-029944	126-029947*	126-029949
<b>Compatible with Roth</b>				
Hooks on Cuspids		126-029945		
Hooks on Cuspids, 1st & 2nd Bicuspids	126-029942	126-029946	126-029950*	126-029951*

Note: All Empower 2 bracket hooks are distal  
\*BX Pad on Bicuspid

## VERTICAL SLOT GIANELLY SYSTEM

	Torq	Ang	R/L	INTERACTIVE .018	PASSIVE .022		
				No Hook	No Hook	With Hook	
<b>MAXILLARY</b>	Central	+12	+5	R L	475-1112VS 475-2112VS		
	Lateral	+8	+9	R L	475-128VS 475-228VS		
	Cuspid	0	+7	R L			585-130BVS 585-230BVS
	1st and 2nd Bicuspid	0	0	R L		585-140VS 585-240VS	585-140BVS 585-240BVS
<b>MANDIBULAR</b>	Anteriors	0	0	R L	475-410VS 475-310VS		
	Cuspid	0	+5	R L			585-430BVS 585-330BVS
	1st and 2nd Bicuspid	0	0	R L		585-440VS 585-340VS	585-440BVS 585-340BVS



Note: All Empower 2 bracket hooks are distal

# Empower<sup>®</sup>2

## Self Ligating Braces

### SALES AND MARKETING AIDS

005-032	Empower Clear Typodont, hooks on 3, 4, 5
005-033	Empower Clear Typodont, hooks on 3's
005-035	Empower Clear 15x model
005-034	Empower Clear Acrylic stick with bracket
005-035	Empower Clear 15x model
005-030758	Empower Clear Upper, Empower Metal Lower Typodont
005-024A	Empower Metal Typodont, hooks on 3, 4, 5
005-024B	Empower Metal Typodont, hooks on 3's
005-027940	Empower Metal Typodont with PowerScope2, hooks on 3, 4, 5
005-026	Empower Metal 15x model, Active
005-027	Empower Metal 15x model, Passive
005-025	Empower Metal Acrylic stick with Active bracket
005-025P	Empower Metal Acrylic stick with Passive bracket
001-033040	Empower Clear bracket debond instrument
678-901C	Empower bracket opening instrument

### PRINTED LITERATURE

LITSL-032022	Empower 2 Clear Patient Brochure
LITSL-032021	Empower 2 Clear Patient Brochure - Trifold
LITSL-032025	Empower 2 Clear Poster 20" x 24"
LITSL-31	Empower 2 Metal Patient Brochure
LITSL-021257	Empower 2 Metal Patient Brochure - Trifold
LITSL-024976	Empower 2 Metal Poster 20" x 24"
LITSL-39	Empower Canvas Art 36" x 48"
LITGEN-04	Empower 2 Patient Brochure easel
LITGEN-031211	Patient Brochure holder - Trifold

Visit [www.americanortho.com](http://www.americanortho.com) or speak with your American Orthodontics Sales Rep for additional Empower 2 marketing assets.





3524 Washington Avenue  
Sheboygan, Wisconsin, 53081 USA

Phone: +1 920 457 5051  
Email: [cs@americanortho.com](mailto:cs@americanortho.com)  
Web: [americanortho.com](http://americanortho.com)



©2021 American Orthodontics Corporation  
All Rights Reserved

FOLLOW US ON



Patent No.: D820,457  
10,912,630